



CHOOSE AN EASY LIFE

Catalog
2017



Smart Light Switch

MindoLife's Smart Light Switch is a smart home unit which is installed over a single existing switching point in the house. While retaining the previous manual switching ability it enables a secured remote control of that switching point over the air and via the internet, allowing it to be monitored and take part in smart scenarios. Scheduled light/s on or of, light switching dependencies with other light switches, moderate lights out regime and countless more configurable smart scenarios to suit one's habits and specific light switching needs. Installation does not require any changes to the home electric grid





OPERATING MANUAL: Mindolife's Single Relay Device
This Manual is valid for the following Mindolife devices

Item	Item No.
Mindolife High voltage relay	#MHVR210v3.2
Mindolife Boiler	#MDB111v3.2
Mindolife Light Switch	#MLS111v3.2
Mindolife Wall Socket	#MWS212v3.2

Mindolife's smart home System General Information

Mindolife's Smart Home is a wireless system based on ZigBee technology.

Mindolife's technology and design approach provide many advantages for the smart home users:

1. Cyber Safe: Mindolife's Smart Home System is a security oriented system. A Cyber protection mechanism layer is part of the smart home system designed to prevent Cyber-attack on your home and also to protect your privacy.

2. Simple For Use: Mindolife's Smart Home is a very easy to use and control system. It is also very easy to install it at any house. A qualified and licensed electrician can easily install it with virtually no changes to the electricity infrastructure of the house.

In general, radio systems create a direct connection between the receiver and transmitter.

But the radio signal is weakened by various obstacles located on its path (apartment walls, furniture, etc.) and in extreme cases it fails to transfer the required data. The advantage of Mindolife system is that its devices apart from being transmitters and receivers of signals are also a signal "duplicators". When a direct connection path between the transmitter and the receiver can not be established, the connection may be achieved through other intermediate devices.

Mindolife is a bi-directional wireless system. It means that the signal is not only sent to the recipients but also that the recipients acknowledge it's reception, which ensures connectivity to be well registered at all time.

Safety of the Mindolife system transmission is comparable to the safety of transmission in data bus wired systems.

Mindolife's smart home system operates in the free band for data transmission at 2.4GHz frequency, In channels higher than those used by Wi-Fi. Every Mindolife Smart Home system has its own unique identification number (home ID).

Therefore, it is possible to operate two or more independent systems in one building without any interference.

Many manufacturers in various industries offer solutions based on ZigBee technology, guaranteeing their compatibility, this means that the system is open and it may be extended in the future.

Single Relay Device General Information

The remotely controlled Single Relay Device of Mindolife's system is designed to operate with a Neutral (Zero) and Live lead (Phase) as power supply. It can operate an electrical devices not exceeding a load of 2500W and sustain up to 12A of current.

Single Relay Device Technical Information

- Controlled by Mindolife's system
- Microprocessor control
- Remembers last switching state / Child lock
- Power switching based on mechanical relay.



DANGER of electrical shock—Installation of the device is to be done only by a qualified and licensed electrician.



DANGER of electrical shock. Even when the device is turned off, voltage could still be present at its terminals. Any changes to the configuration of the connections or the load must always be performed with voltage OFF and disconnected to the device installation location (disable the fuse).



DANGER. The device might get damaged if the values of the applied load are inconsistent with the technical specifications (see Specifications). Connect only in accordance with the diagram presented in the manual. Incorrect connection could cause risk to health, life or material damage.

Connecting the Single Relay Device



Before installation make sure that the voltage line is OFF and disconnected in the chosen location of installation.

1- Connecting the "Mindolife Wall Socket" : Just plug it into the wall and you're done.

2- Connecting the other Mindolife items: Connect the Single Relay Device according to the diagram below. Place all elements in the electrical box as before. In case it is not possible to accommodate the device within the standard wall socket it is possible to connect it to the wall outside the wall socket and draw the relevant wires to it.

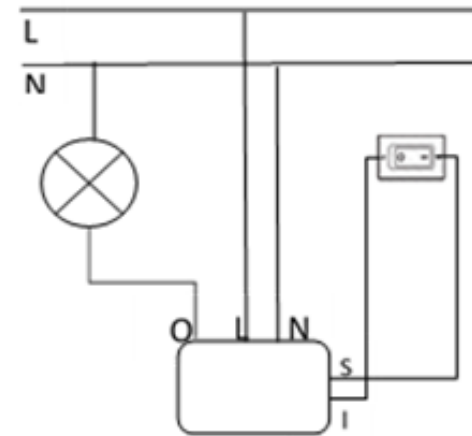

Figure 1 Diagram for connecting the device

L – line lead (Phase- brown wire)
N – neutral lead (blue wire)
O – output lead
S / I – Single Relay Device ON/OFF control.

Note - The length of wires used to connect the control switch should not exceed 20m.

Activating the Single Relay Device

After connecting Mindolife Base Unit as it explained in "Mindolife Base Unit Manual", perform the following steps:

- 1- Sign in to Mindolife application.
- 2- Scan the QR-code of the device using the application.
- 3- Connect the device in accordance with the circuit diagram presented in Figure 1.

Operating the Single Relay Device

The Single Relay may be operated using the following control elements:

- a mobile phone (e.g. iPhone and phones from other manufacturers with appropriate software) .
- devices of tablet type.
- PC, using a web browser.
- via push-buttons connected to outputs S and I.

Specifications

AC Line Input	85-240 volt 50/60 Hz
Relay Rating	16 A at 250 VAC (maximum absolute rating)
Operating Temperature	Operating: -15°C to 50°C Storage: -25°C to 65°C
Dimensions	23x45x52 mm
Plastic Type	ABS
Electricity consumption	less than 0.8W
Radio protocol	ZigBee
Radio Frequency	2.4Ghz
RF Range	50 m (between two devices)

Appendix A: Troubleshooting

1. It is not possible to control the electrical end device using the switch connected to the Single-Relay end device:
 - Make sure that the Single-Relay end device is properly connected via its line (2) and neutral (3) connection and that it is powered up (see the Single-Relay connection diagram).
 - Make sure that the physical switch is properly connected.
2. It is not possible to control the Single-Relay device remotely:
 - Make sure the device is powered up
 - Make sure that the location of installation does not exceed a range of 50 meters from the last remotely connected end device and/or the Smart-Home Operator-Device.
 - It is possible to take the following measures in order to improve chances of connectivity:
 - i. Change the position in which the Single-Relay end device resides in its place of connection.
 - ii. Move the Single-Relay end device closer to the plastic cover of the connection point.
 - iii. Distance all power wires away from it as far as possible at the point of connection.
 - iv. Move away obscuring objects (especially metallic) from its nearby surroundings.

- It is possible to decrease distances for better connectivity chances
 - i. To the Smart-Home Operator unit (installing the Single-Relay end device in a closer location to it).
 - ii. To another end device which is remotely reachable by the Smart-Home operator unit.
 - iii. Installing another end device topologically residing in between the Smart-Home operator and the Single-Relay end device (making sure that it is reachable by the Smart-Home operator unit in itself).